

Gocator® 3506

3D SMART SNAPSHOT SENSOR

Gocator 3506 is the highest-resolution 3D snapshot sensor on the market. Its resolution and repeatability make it ideal for the accurate inspection of small parts such as electronic components. An excellent solution for inline factory automation, this all-in-one smart snapshot sensor offers high resolution for accurate measurements down to 12 μm^* using a stereo camera and an industrial projector to deliver long lifetime and uniform lighting within the measurement volume.

» 3D POINT CLOUDS IN A SINGLE SNAPSHOT

» ACCURATE 3D MEASUREMENT WITH BLUE LIGHT PROJECTION

» INDUSTRIAL DESIGN FOR LONG LIFE

* Based on VDI/VDE 2634, Part 2



Gocator 3506

HIGH ACCURACY

The sensor's stereo 5-megapixel camera lets you measure small features in a single snapshot, with the highest resolution and accuracy for an industrial structured light sensor on the market today. With snapshot sensors, the target is stationary during acquisition effectively minimizing the cost of expensive motion system components (such as encoders) and the associated errors due to vibration.

INLINE INSPECTION READY WITH FASTER PROCESSING

The sensor's new dual core controller and onboard hardware acceleration allows for inline production speeds. Using Gocator Accelerator (GoX), the Gocator 3506 runs up to 4x faster than sensor only operation to achieve inline scan rates of 3 Hz.

EASY TO USE

Gocator's built-in GUI provides an intuitive setup experience, using any web browser, computer or operating system. No additional software is required.

INDUSTRIAL PACKAGE, COMPACT, AND LIGHTWEIGHT

Gocator's rugged IP67 housing, small form factor, and light weight make it ideal for fitting into small spaces and mounting on robots.

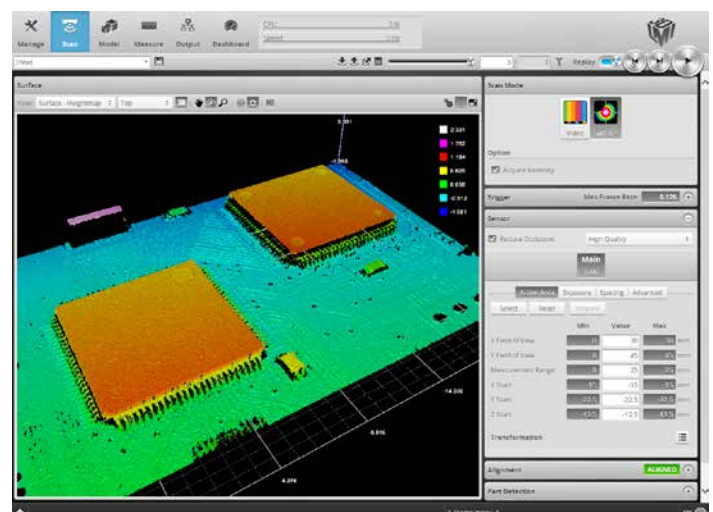

Gocator's browser-based graphical user interface showing the detail of a small electronics part

INDUSTRIAL PROJECTOR FOR LONG LIFETIME

The sensor's LED light source makes it easier to work with than lasers. The bright LED and industrial design enables shorter exposures, so you get measurements faster with an expected lifetime of up to 10 years of continuous operation.

Gocator 3506 Specifications	
Scan Rate (Hz)	3
Imagers (megapixels)	5
Clearance Distance (CD) (mm)	87.0
Measurement Range (MR) (mm)	25.0
Field of View (mm)	27.0 x 45.0 - 30.0 x 45.0
Repeatability Z (um)	2.0
Resolution XY (mm)	0.020 (CE) - 0.025 (FE)
VDI/VDE Accuracy (mm)*	0.012
Dimensions (mm)	49 x 136 x 170
Weight (kg)	1.52
Light Source	Blue LED (465 nm)
Interface	Gigabit Ethernet
Inputs	Differential Encoder, Trigger
Outputs	2x Digital Output, RS485 Serial (115 kbaud), 1x Analog Output (4 - 20 mA)
Input Voltage (Power)	+24 to +48 VDC (25 Watts); RIPPLE +/- 10%
Housing	Gasketed Aluminium Enclosure, IP67
Operating Temp	0 to 50 °C
Storage Temp	-30 to 70 °C
Vibration Resistance	10 to 55 Hz, 1.5 mm double amplitude in X, Y and Z directions, 2 hours per direction
Shock Resistance	15 g, half sine wave, 11 ms, positive and negative for X, Y and Z directions

Software and Built-in 3D Measurement Tools	
3D Feature Tools	Openings (holes, slots), Cylinders, Studs (threaded and non-threaded), Plane
3D Volumetric Tools	Volumes, Areas, Bounding boxes, Positions (min, max, centroid), Ellipses, Orientations
Scanning Software	Browser-based GUI and open source SDK for configuration and real-time 3D visualization. Open source SDK, native drivers, and industrial protocols for integration with user applications, third-party image processing applications, and PLCs.

* Based on 2634, Part 2

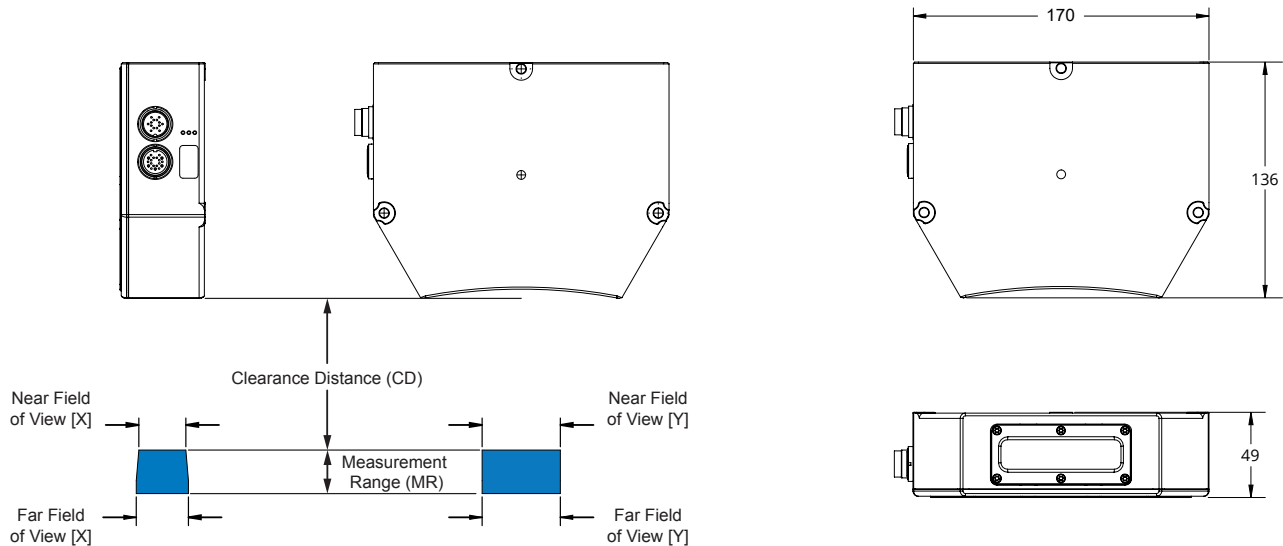

KANSAS CITY, MO

913.440.4477

SPRINGFIELD, MO

417.724.2231

ST. LOUIS, MO

314-731-4444

BLOOMINGTON, IL

217.615.4440